

SBN 45 syrefastepumper

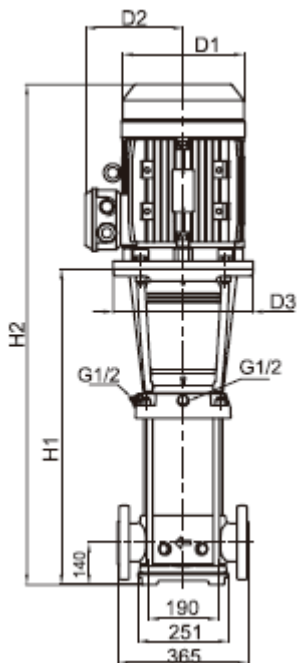

50Hz Pump type	Motor		Nominal current [A]				Dimension [mm]			Net weight [kg]		
	P ₂ [kW]	[HP]	3ø		3ø		DIN flange					
			Δ220-240V	Y380-415V	Δ380-415V	Y660-720V	H1	H2	D1	D2	D3	DIN flange
SBI(N) 45-2	7.5	10	25.5 - 24.9	14.7 - 14.4	14.9 - 14.8	8.6 - 8.5	639	1044	235	197	300	114.7
SBI(N) 45-3	11.0	15	38.8 - 39.1	22.4 - 22.6	22.9 - 23.8	13.2 - 13.7	829	1274	269	215	350	155.7
SBI(N) 45-4	15.0	20	49.3 - 46.5	28.5 - 26.9	24.9 - 29.0	16.9 - 16.7	909	1399	269	215	350	170.1
SBI(N) 45-5	18.5	25	60.2 - 55.4	34.8 - 32.0	35.2 - 33.5	20.3 - 19.3	989	1529	318	241	350	198.8
SBI(N) 45-6	22.0	30	71.3 - 67.5	41.2 - 39.0	41.3 - 39.6	23.8 - 22.8	1069	1609	318	241	350	223.3

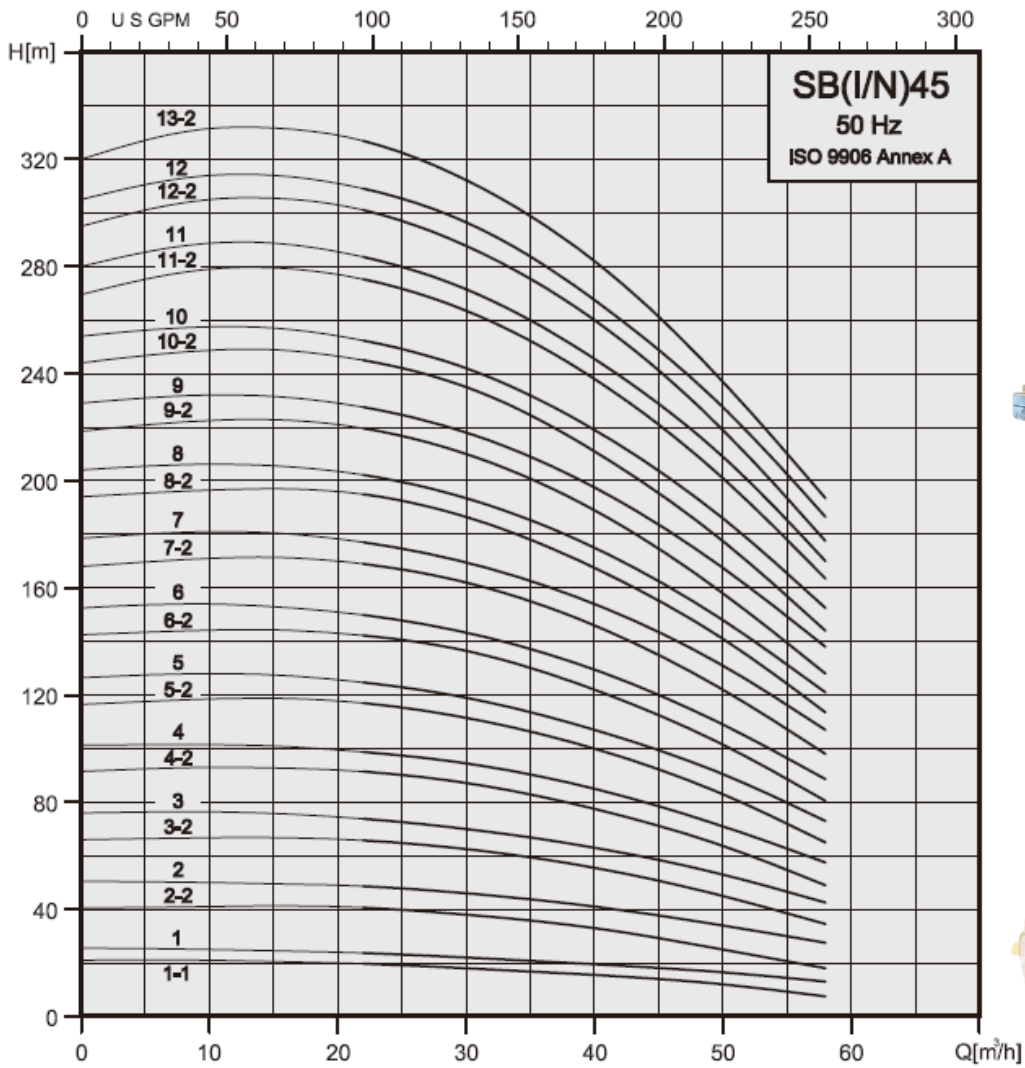
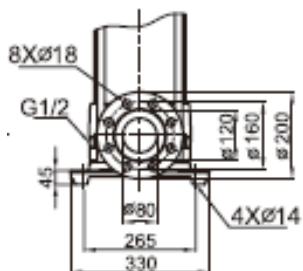

BRØDR. FREBERG AS

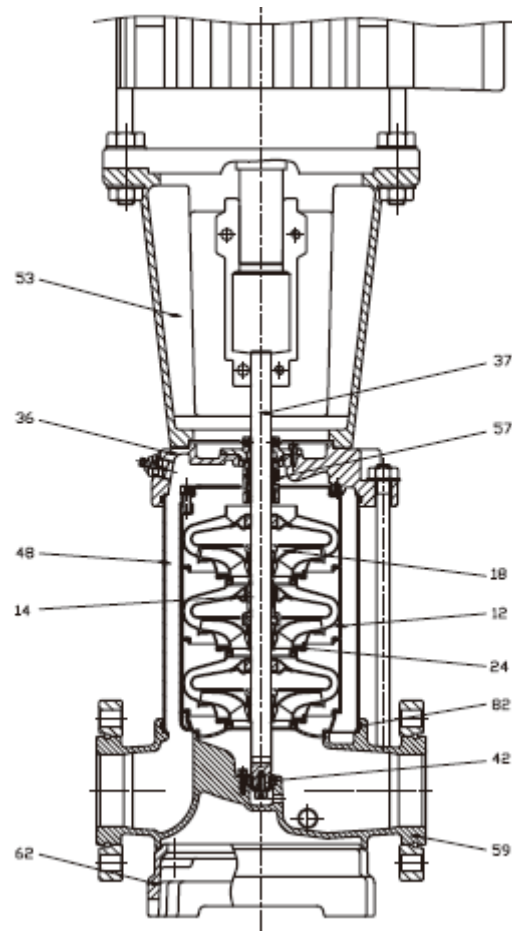

Pos.	Name	Material	SBN 32, 45, 64, 90	
			Standard	
			Europe	USA
36	Pump head	Cast Iron		
		Stainless steel	1.4401	AISI 316
53	Motor Bracket	Cast Iron	EN-GJL-250	ASTM 35B
18	Impeller	Stainless steel	1.4401	AISI 316
37	Shaft	Stainless steel	1.4401	AISI 316
48	Outer Sleeve	Stainless steel	1.4401	AISI 316
82	O-ring for outer sleeve	EPDM		
12	Chamber	Stainless steel	1.4401	AISI 316
24	Neck ring	Carbon Fiber + POB + PTFE		
59	Base	Cast Iron		
	Base	Stainless steel	1.4401	AISI 316
62	Base plate	Cast Iron	EN-GJL-250	ASTM 35B
57	Mechanical seal	Cartridge type		
14	Bearing ring		POB+Graphite+PTFE	
42	Bottom bearing ring	Tungsten carbide/ Tungsten carbide		

**f BRØDR.
FREBERG AS**

Tlf. 33 30 86 60 www.freberg.no post@freberg.no