

*Technical data sheet*



**FEATURES:**

- *Threads according to ISO 228/1 (DIN 259)*  
*ACS CERTIFIED*

■ **USE:**

*Guaranteed for the use of cold and hot water*

■ **MATERIALES:**

*Body in brass CW617N (UNE EN 12165)*

*Sand-blasting finishing*

*Sealing face: the hexagonal plug in oiled chipboard washer  
inspection plug in NBR.*

■ **TECHNICAL LIMITS:**

*Max. Temp: 70°C*

*Min. Temp: 0°C*

*PN 12 bar (150 PSI)*

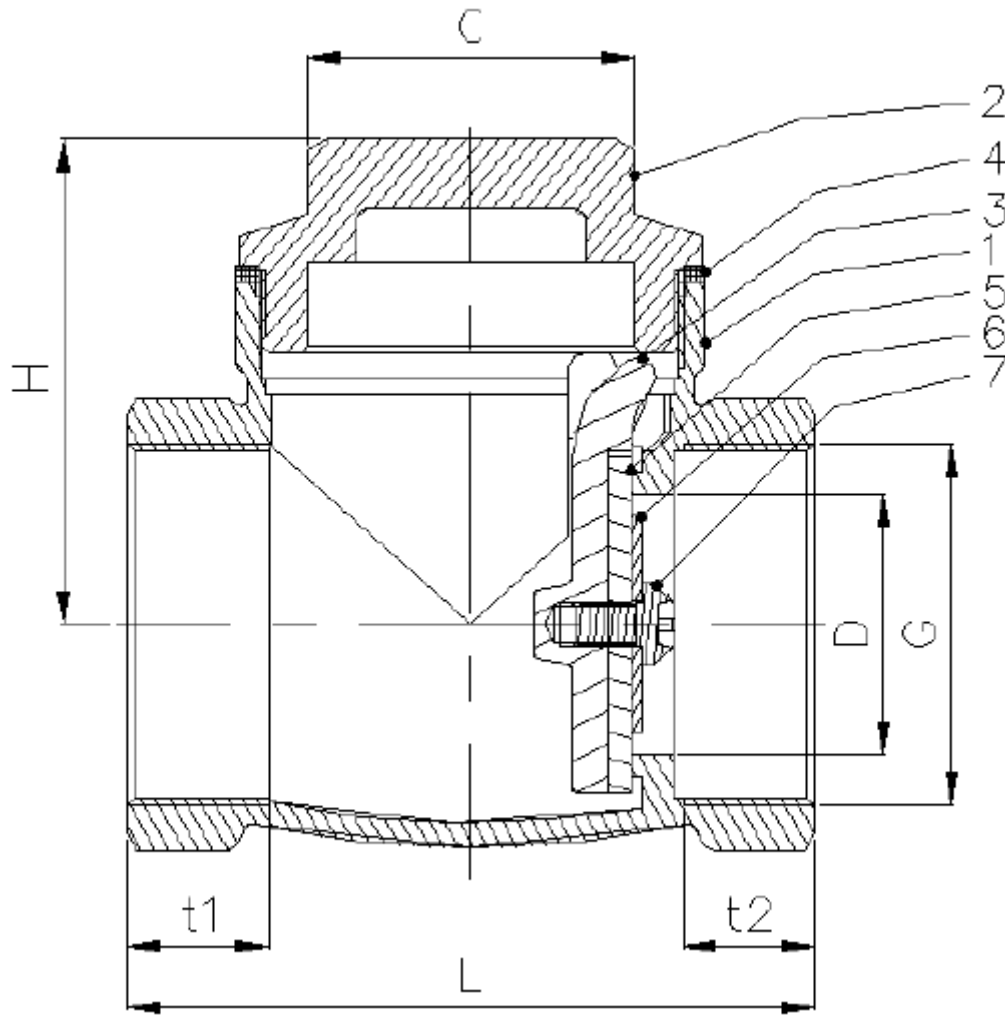

N°	Name	Material
1	Body	Brass
2	Bonnet	Brass
3	Disco	Brass
4	Washer	Fiber
5	Seal	NBR
6	Gasket	Stainless Steel
7	Bolt	Brass

DT	DN	t1 & t2	H	L	C
1/2"	13,5	11,5 & 11,5	33,5	48	22
3/4"	20	10 & 10	40	52	26
1"	24	13 & 12	44,5	63	27
1 1/4"	32	15 & 14	52	74	34
1 1/2"	38	16 & 14	64	86	40
2"	47	16 & 16	67	98	49
2 1/2"	60	22 & 21	80	120	63
3"	70	22,5 & 22,5	92	135	77
4"	86	27 & 26	103	160	95